

INTERSTATE **PAVER SERIES**



SIDE LOAD FRONT
DECK FOR PAVER

REAR LOADING
FOR ROLLER OR
SKID STEER

SIDE MOUNTED JACKS
FOR STABLE LOADING

HIGH CAPACITY
17.5" TIRES

2" HARDWOOD
DECKING

HEAVY DUTY SPRING
SUSPENSION

LED LIGHTS & SEALED
MODULAR WIRING

RUST PROHIBITIVE
UNDERCOATING

THE
DEFINITION
OF VALUE

14PBS / 20PBS

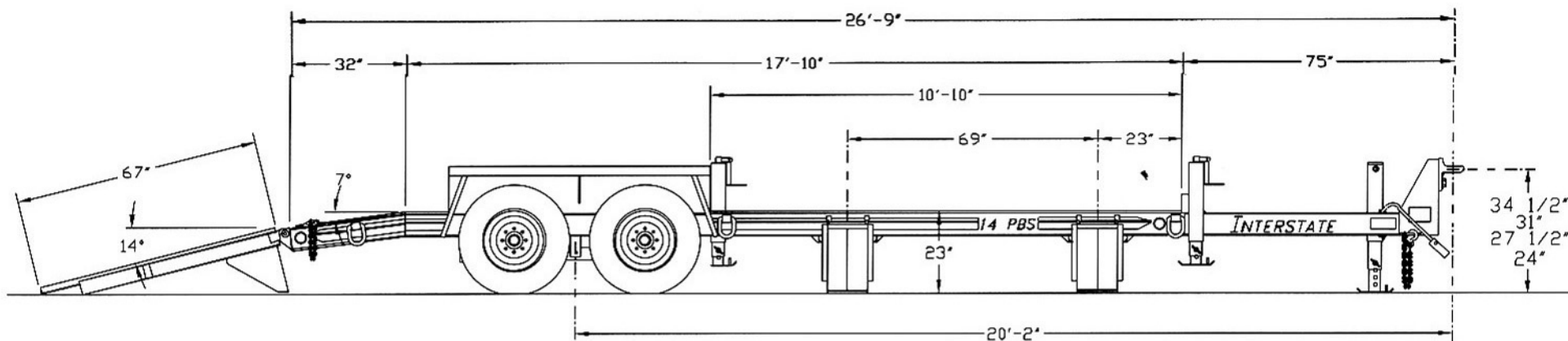

MODELS: 14PBS
*** (20PBS)**

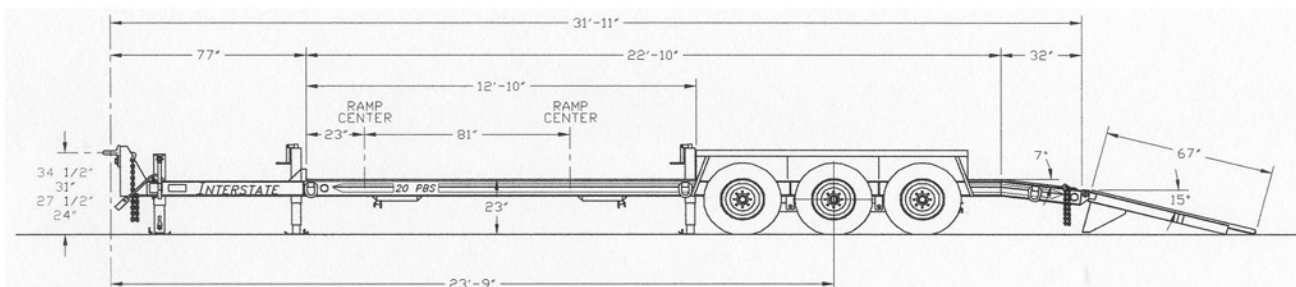

CAPACITY:	
14PBS:	14,000 lbs. @ 65 mph
20PBS:	20,000 lbs. @ 65 mph
Trailer Weight:	4,800# *(5,500#)
Overall Length:	26' 9" *(31'-11")
Overall Width:	102"
Platform Length:	20' 6" *(25'-6")
Platform Width:	102"
Width Between Fenders:	80"
Platform Height:	23"
Dovetail Length:	32"
Ramp Length (Rear):	67"
Ramp Width (Rear):	21 1/2"
Ramp Length (Side):	77 1/2"

Ramp Width (Side):	13 7/8"
Decking:	2" Nominal Hardwood
Main Rails:	W6" x 16# A572 Gr. 50 Hi-Tensile
Crossmembers:	4" x 3.2# I Beam Gr. 50 Hi-Tensile
Heavy Duty Axles:	8,000# - 4" Drop
Heavy Duty Brakes:	Electric - 12 1/4" x 3 3/8"
Heavy Duty Suspension:	Spring Type
Tires:	215/75R x 17.5 - 16PR Radial
Heavy Duty Wheels:	6.75 x 17.5 8 Bolt Disc
Lights & Electric:	Sealed Beam System/ICC & DOT Approved
Hitch:	Adjustable Pintle Eye - 4 Position

Gel Cell Break-A-Way Switch System with Battery
 Heavy Duty Jack: 12,000 # Screw Type

Interstate Trailers, Inc. reserves the right to change design, material and/or specifications without notice and without incurring any obligation to such changes.

Your **INTERSTATE** Dealer Is