

INTERSTATE

THE
PERFECT
CONNECTION



FEATURES

- EASY ONE-MAN OPERATION
- LOW PROFILE LOAD ANGLE
- TWIN CUSHION CYLINDERS
- SEALED BEAM LIGHTING SYSTEM



20APC

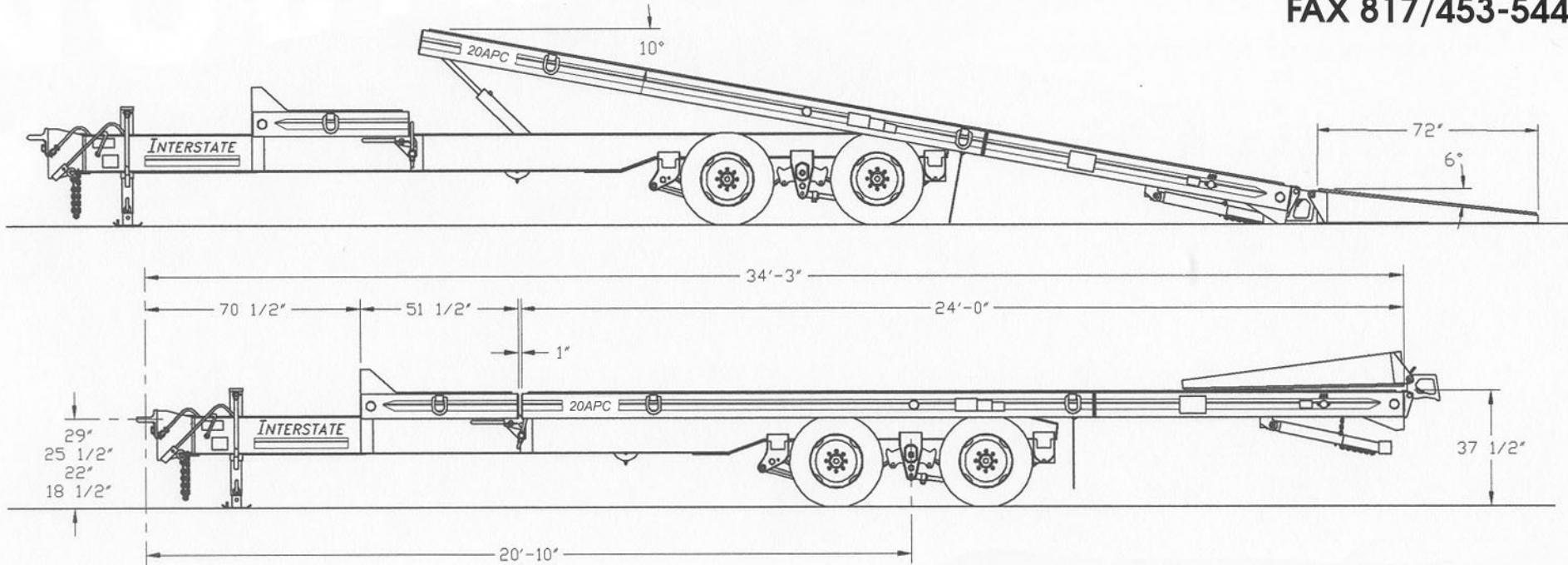

Model: 20APC

CAPACITY: 20,000# @ 65 MPH
 Overall Weight: 5,950#
 Overall Length: 34' 4 1/2"
 Overall Width: 96"/102"
 Platform Length: 24' 0"
 Stationary Deck: 51 1/2"
 Platform Height: 38"
 Paver Ramps: 72" (spring assisted)
 (2" nominal hardwood)
 Decking: 2" Nominal Hardwood
 Hitch: Adjustable Pintle Eye
 Cushion Cylinder: 2 (3 1/2" diameter)

Main Rail: Tilt Bed - W8" x 15# A572 Gr. 50 High Tensile
 Chassis: W12" x 19# A572, Gr. 50 Hi-Tensile
 Crossmembers: Tilt Bed - S6" x 12.5# A572 Gr. 50 High Tensile
 Chassis: 4" x 4" Square Tube A500B
 Heavy Duty Axles: (2) "Dexter" 10,000#
 Heavy Duty Brakes: Air, 12-1/4" x 4" with ABS
 Heavy Duty Suspension: Hutch 9700
 Tires: (8) 235/80R16, (E) Goodyears
 Heavy Duty Wheels: 8 hole, Steel Disc
 Lights & Electric: Sealed Beam System/ICC &
 DOT Approved
 Heavy Duty Jack: 12,000# Drop Leg

Your **INTERSTATE** Dealer Is