

# **INTERSTATE**

THE  
PERFECT  
CONNECTION

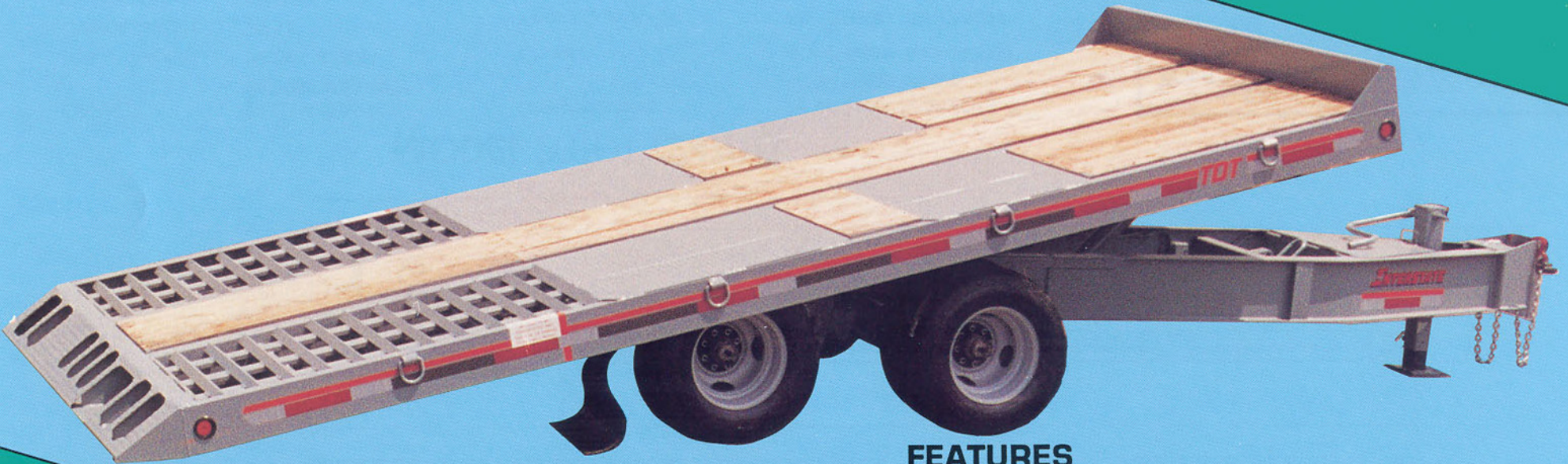

## FEATURES

- TAPERED REAR END WITH RECESSED LIGHTS
- NEW UNDERRIDE PROTECTION
- STRAIGHT-THRU CHASSIS DESIGN
- HEAVY DUTY CUSHION CYLINDER
- WHEEL TRACTION PATHS

# 24TDT



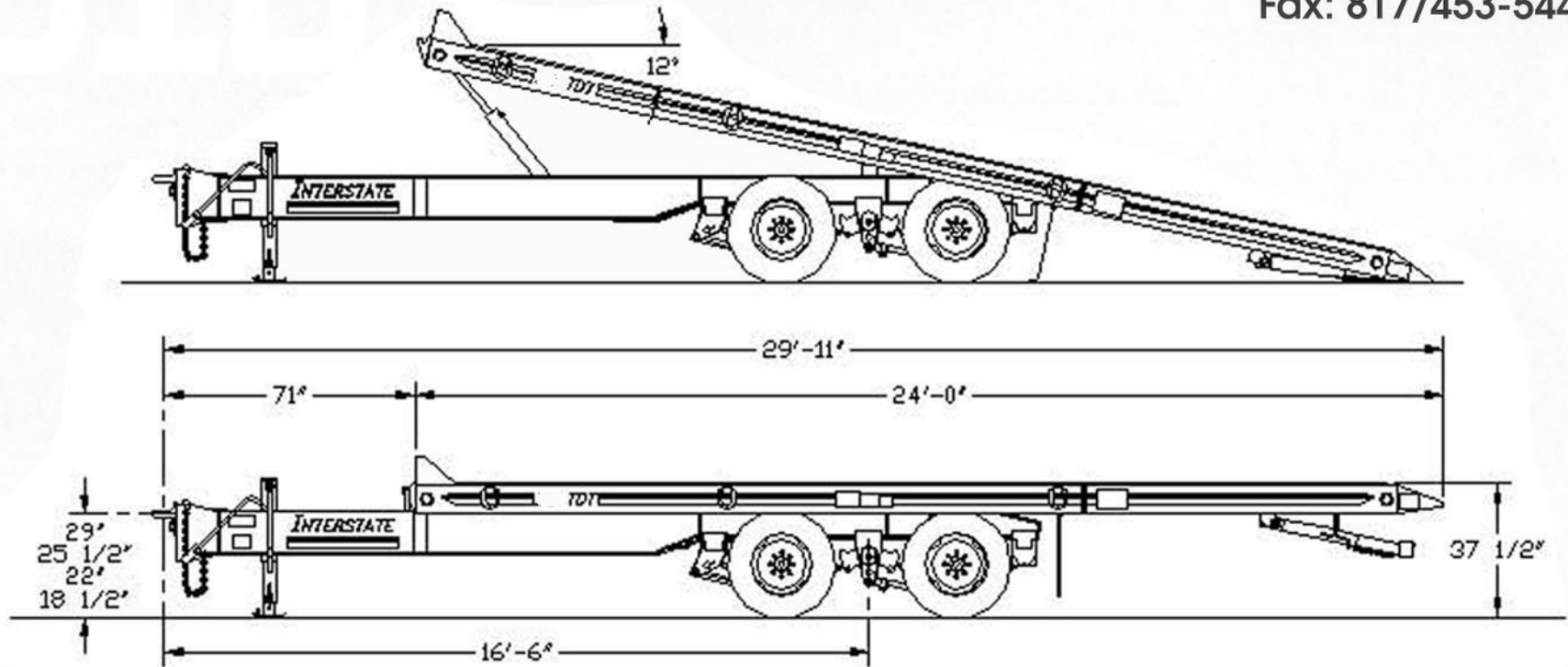

## MODEL 24TDT

CAPACITY:	24,000# @ 65 MPH	Crossmembers:	Tilt Bed S6 x 12.5# A572 Gr 50 - High Tensile
Trailer Weight:	6,500#	Chassis:	4" x 4" Square Tube A500B
Overall Length:	29'-11"	Heavy Duty Axles:	(2) 12,000#
Overall Width:	96"/102"	Heavy Duty Brakes:	Electric, 12-1/4" x 5"
Platform Length:	24'-0"	Heavy Duty Suspension:	H9700
Platform Height:	37 1/2"	Tires:	235/85R16 - 14 ply Radial
Decking:	2" Nominal Hardwood	Heavy Duty Wheels:	Dual "Budd" Type
Main Rails:	Tilt Bed - W8" - 15# A572 Gr 50 - High Tensile	Lights & Electric:	Sealed Beam System/ ICC & Dot approved
Chassis:	W12" x 19# A572 Gr 50 High Tensile	Hitch:	Adjustable Pintle Eye

Your **INTERSTATE** Dealer Is

Gel Cell Break-A-Way Switch System with Battery • Heavy Duty Jack: 12,000# Screw Type

Interstate Trailers, Inc. reserves the right to change design, material and/or specifications without notice and without incurring any obligation to such changes.