

INTERSTATE



30DLE

**THE
DEFINITION
OF VALUE**

**CONTINUOUS PIERCED
MAIN BEAM WITH
INTERLOCKING
CROSSMEMBERS
SYSTEM**

**SEALED BEAM
ELECTRICAL SYSTEM**

**HEAVY DUTY
ELECTRIC BRAKES**

**HEAVY DUTY SPRING
SUSPENSION**

**FRONT HEAD
BOARD STOP**

UNDERCOATED

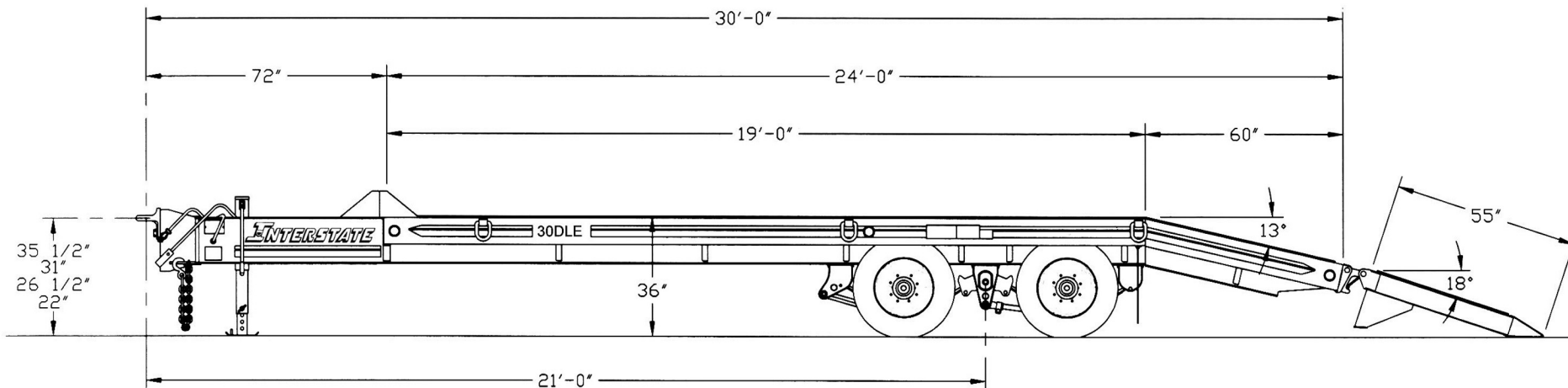

Model: 30DLE

CAPACITY: 30,000 lbs. @ 55 M.P.H.
 Trailer Weight: 7,600#
 Overall Length: 30' 0"
 Overall Width: 96"/102"
 Platform Length: 24' 0"
 Platform Height: 36"
 Dovetail Length: 60"
 Ramp Length: 55"
 Ramp Width: 22 1/2"
 Decking: 2" Nominal Hardwood

Main Rails: W14" x 22# A572 Gr. 50 High Tensile
 Crossmembers: 6" Jr. I-Beam A572 Gr. 50 High Tensile
 Heavy Duty Axles: (2) 15,000 lb. Dexter
 Heavy Duty Brakes: 12-1/4" x 5" Electric
 Heavy Duty Suspension: H9700
 Tires: (8) 215/75R x 17.5 - 16 Ply Radial
 Heavy Duty Wheels: 10 hole steel disc
 Lights & Electric: Sealed Beam System/ICC & DOT Approved
 Hitch: Adjustable Pintle Eye
 Heavy Duty Jack: 12,000# Drop Leg

Your **INTERSTATE** Dealer Is