

# INTERSTATE TRAILERS, INC

70,000 lbs. Load Capacity in 16'

Four Cambered I-Beam Design

235/75R17.5 (H) Tires On Steel Disc Wheels

Hydraulic Tail With 14° Load Angle

Apitong Decking



## 70PHT

For Nearest Dealer Call: 800-433-5384

Full Width Neck With 17° Slope

Hydraulic Winch With Wireless Remote

THE DEFINITION OF VALUE

### INTERSTATE TRAILERS, INC.

MODEL: 70PHT

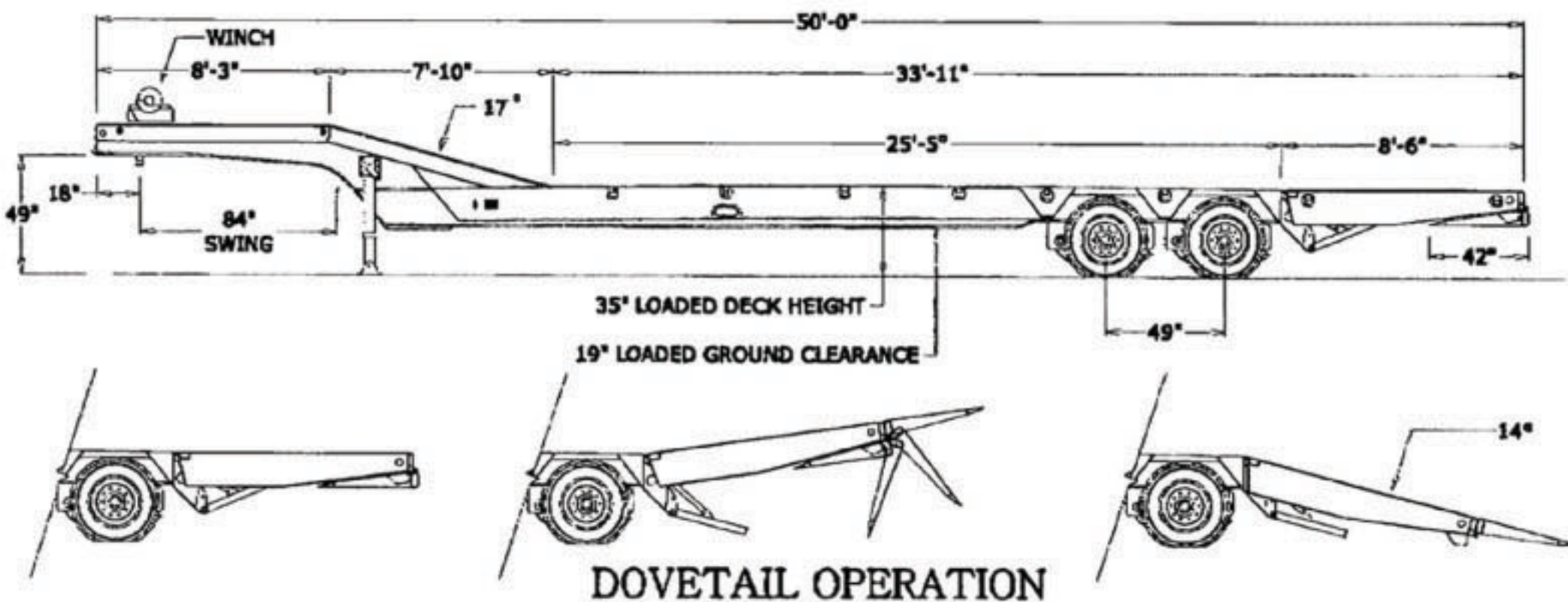

DOVETAIL OPERATION

Load Capacity: 70,000 lbs.  
 Weight: 17,900 lbs.  
 Overall Length: 50'-0".  
 Width: 8'-6".  
 Deck Length: 25' + 8'-6" Tail.  
 Deck Height: 35" Loaded.  
 Gooseneck: Flat Deck - Wood with 17 Degree Slope - Steel With Traction Bars. 49" Fifth Wheel Hgt., 18" King Pin Setting, 84" Swing.  
 Mainframe: (4) 16" Fabricated I-beams  
 Crossmembers: Located on 20" Centers.  
 Wheel Wells: Covered With Diamondplate.  
 Hydraulic Tail: Load Angle - 14 degrees.

Power Source: Set Up For Wetline.  
 Winch: 12,000 lb. With Wireless Remote.  
 Landing Gear: 2 Speed, 50,000 lb. Capacity.  
 Tool Box: Lockable In Gooseneck.  
 Lashing Rings: 10 Per Side, 20 Total.  
 Decking: 1-3/4" Apitong.  
 Suspension: Air Ride with Auto & Manual Controls.  
 Axles: 25,000 lb. Capacity, 77.5" Track.  
 Tires: 235/75R17.5 (H).  
 Wheels: 6.75 x 17.5 Steel Disc.  
 Brakes: 12-1/4" x 7-1/2" Air With Auto Slacks.  
 Wiring: D.O.T. Sealed Wiring Harness With LED Lights.  
 Paint: Black Polyurethane.