

# **INTERSTATE**



## **G50TDL-3**

**THE  
DEFINITION  
OF VALUE**

**TAPERED REAR END  
WITH RECESSED  
LIGHTS**

**LED LIGHTS & SEALED  
MODULAR WIRING**

**HEAVY DUTY SPRING  
SUSPENSION**

**(2) HEAVY DUTY  
CUSHION CYLINDERS**

**8 HOLE, HUB PILOTED  
STEEL DISC WHEELS**

**STRAIGHT-THRU  
CHASSIS DESIGN**

**"NHTSA" APPROVED  
UNDERRIDE  
PROTECTION**

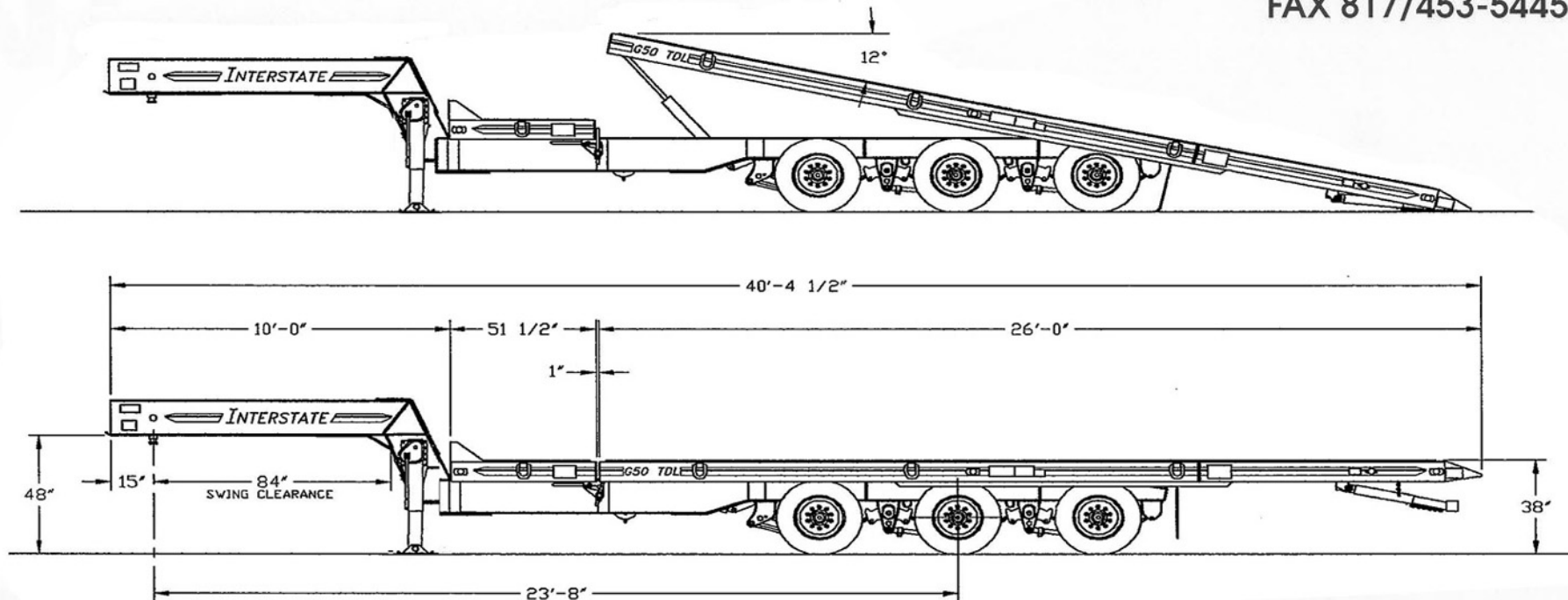

**MODEL: G50TDL-3**

CAPACITY: 50,000 lbs. @ 55 mph  
 Trailer Weight: 14,400#  
 Overall Length: 40'-4"  
 Overall Width: 102"  
 Platform Length: 26' Tilt + 4' Stationary  
 Platform Width: 102"  
 Platform Height: 38"  
 Decking: 2" Nominal Hardwood  
 Hitch: 2" SAE King Pin  
 Main Rails: Tilt Bed W-8" x 15"# A572  
 Gr. 50 High Tensile  
 Chassis: W14" x 26# A572 Gr. 50  
 High Tensile

Crossmembers: Tilt Bed - S6" x 12.5# A572 Gr.50  
 High Tensile  
 Side Rails: C8" x 13.75#  
 Heavy Duty Axles: (3) 22,500 # Oil Bath  
 Heavy Duty Brakes: 12 1/4" x 7 1/2" Air - ABS  
 Heavy Duty Suspension: Hutch 9700 -3  
 Tires: (12) 215/75R17.5, (H)  
 Heavy Duty Wheels: 8 Bolt, Hub Piloted Disc  
 Lights & Electric: LED Lights, with Sealed, Modular  
 Wiring System, DOT Approved  
 Landing Gear: Dual 2 Speed, 50,000 # Capacity

Your **INTERSTATE** Dealer Is