

INTERSTATE



ONE PIECE
MAIN RAIL DESIGN

HEAVY DUTY
SPRING SUSPENSION

12" X 2"
ELECTRIC BRAKES

235/80R16, (E) TIRES
ON DISC WHEELS

DEXTER 6K AXLES

10K HEAVY DUTY
DROP LEG JACK

THE
DEFINITION
OF VALUE

12BST-S

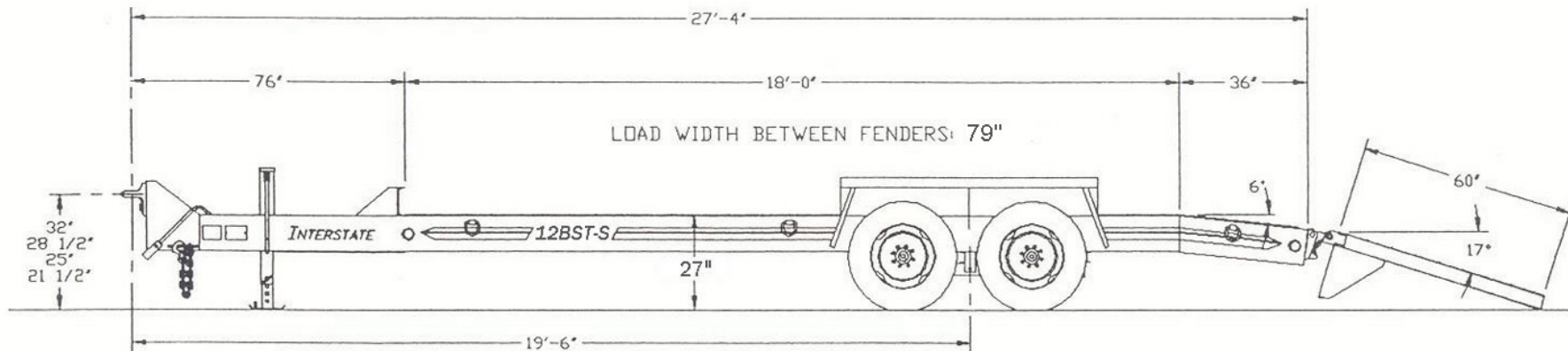

Model: 12BST-S

CAPACITY:	12,000 lbs. at 65 mph.	Main Rails:	C10" x 15# Gr. A36-High Tensile
Trailer Weight:	4800#	Crossmembers:	6" Jr. I Beam - High Tensile
Overall Length:	27'4"	Heavy Duty Axles:	(2) Dexter, 6,000 lb. capacity.
Overall Width:	102"	Heavy Duty Brakes:	12" x 2", Electric
Platform Length:	21'-0"	Jack:	12,000# Drop Leg
Platform Height:	27" unloaded.	Heavy Duty Suspension:	Multi Point Spring
Dovetail Length:	3'-0"	Tires:	(4) 235/85R16, (E)
Ramp Length:	48"	Heavy Duty Wheels:	8 Hole Steel Disc
Ramp Width:	21 1/2"	Lights & Electric:	Sealed Beam System ICC/DOT Approved
Decking:	2" Nominal Hardwood	Hitch:	Adj. Pintle Eye, 4 Position

Gel Cell Break-A-Way Switch System

Your **INTERSTATE** Dealer Is