

INTERSTATE

THE

PERFECT

CONNECTION



- 16' Tilting Platform
 - 12,000 lb. Carrying Capacity
 - 235/80R16 (E) Tires on Disc Wheels
 - Electric Brakes on Both Axles
 - LED Lights & Sealed Wiring Harness

12TST

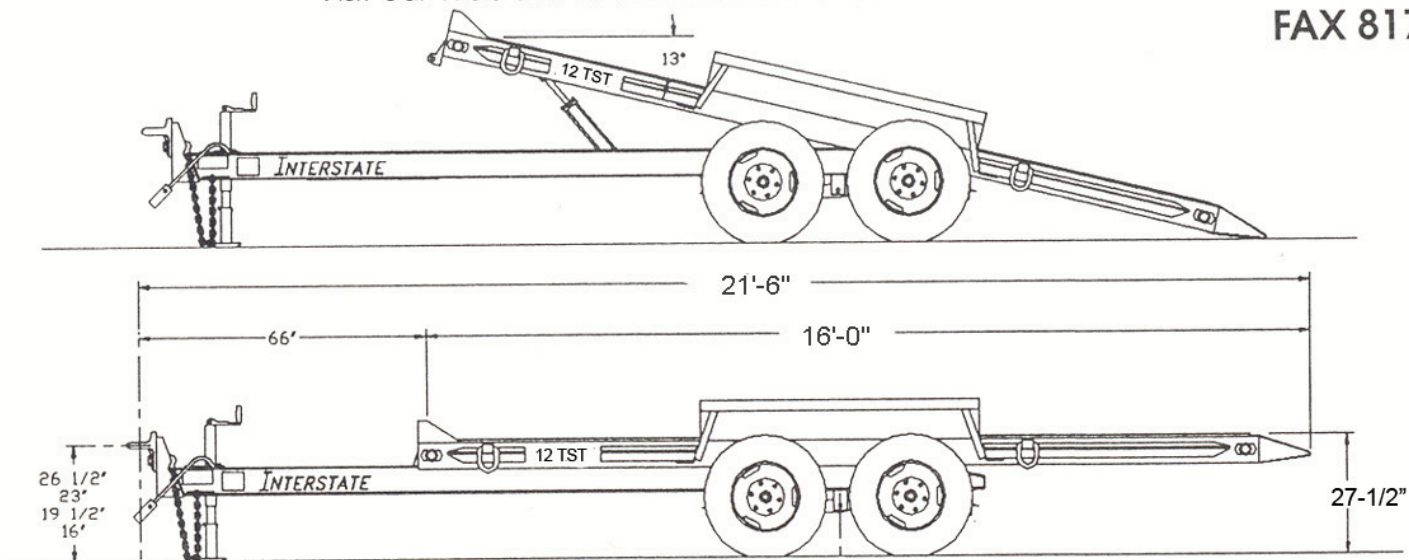
**Model: 12TST**

CAPACITY:	12,000 lbs. @ 55 mph.	Hitch:	Adjustable Pintle Eye
Trailer Weight:	3600#	Heavy Duty Axles:	(2) 6,000#
Overall Length:	21'-6"	Heavy Duty Brakes:	Electric 12" x 2" - Each Wheel
Overall Width:	102"	Heavy Duty Suspension:	Spring Type
Platform Length:	16'-0"	Tires:	(4) LT235/80R16, (E)
Platform Width:	80-1/2"	Wheels:	(4) 8 hole, 16 x 6
Platform Height:	27-1/2" Unloaded	Lights & Electric:	Sealed Beam System / ICC & DOT Approved
Jack:	10,000 lb. Drop leg	Crossmembers:	SLB 4" - 3.2#, 18" Centers
Decking:	2" Nominal Hardwood		
Main Rails:	W6" - 16# I-beam		
Bed Frame:	C6" - 8.2# Channel		

Gell Cell Break-A-Way System with Battery

Your **INTERSTATE** Dealer Is