

INTERSTATE



18BST

18,000 LB. CAPACITY

HEAVY DUTY
ELECTRIC BRAKES

SEALED BEAM
ELECTRICAL SYSTEM

DISC WHEELS - 8 BOLT

EASY O'BACK RAMP
SPRING

CONTINUOUS MAIN
BEAMS

12,000 LB. AVAILABLE-
12BST TANDEM AXLE
DESIGN

THE
DEFINITION
OF VALUE

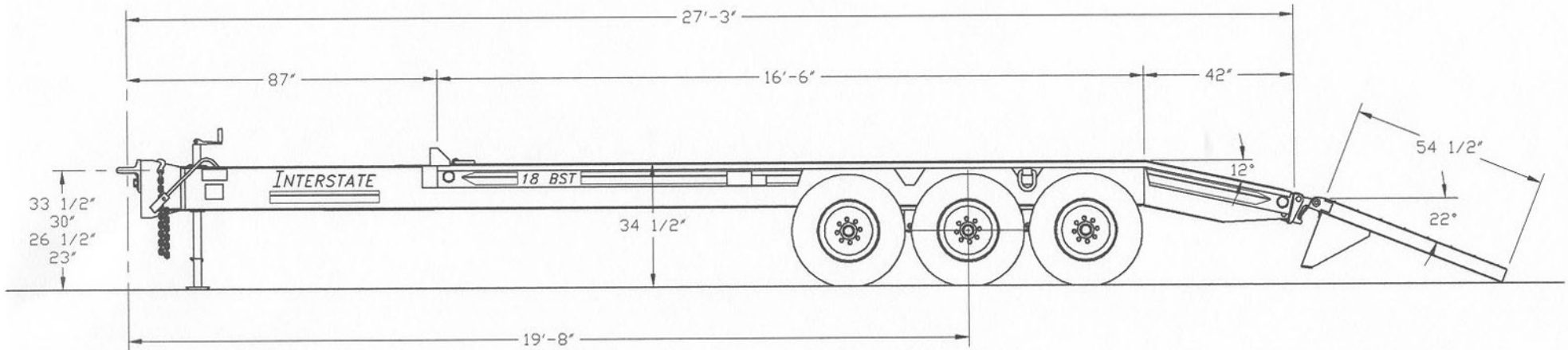

Model: 18BST

CAPACITY:	18,000# @ 55 MPH	Main Rails:	W12" x 16" A572 Grade 50 - High Tensile
Trailer Weight:	4850#/	Crossmembers:	6" Jr. I Beam - High Tensile
Overall Length:	27' 3"	Heavy Duty Axles:	(3) 6,000#/
Overall Width:	96"/102"	Heavy Duty Brakes:	Electric 12" x 2" - Each Wheel
Platform Length:	20' 0"	Heavy Duty Jack:	5,000# Screw Type
Platform Height:	34"	Heavy Duty Suspension:	Spring Type
Dovetail Length:	42"	Tires:	235/85R x 16 - 10 Ply Radial
Ramp Length:	54 1/2"	Heavy Duty Wheels:	8 Hole "Budd" Type
Ramp Width:	21 1/2"	Lights & Electric:	Sealed Beam System /ICC & Dot approved
Decking:	2" Nominal Hardwood	Hitch:	Adjustable Pintle Eye

Gel Cell Break-A-Way Switch System with Battery

Interstate Trailers, Inc. reserves the right to change design, material and/or specifications without notice and without incurring any obligation to such changes.

Your **INTERSTATE** Dealer Is