

INTERSTATE

THE

PERFECT

CONNECTION

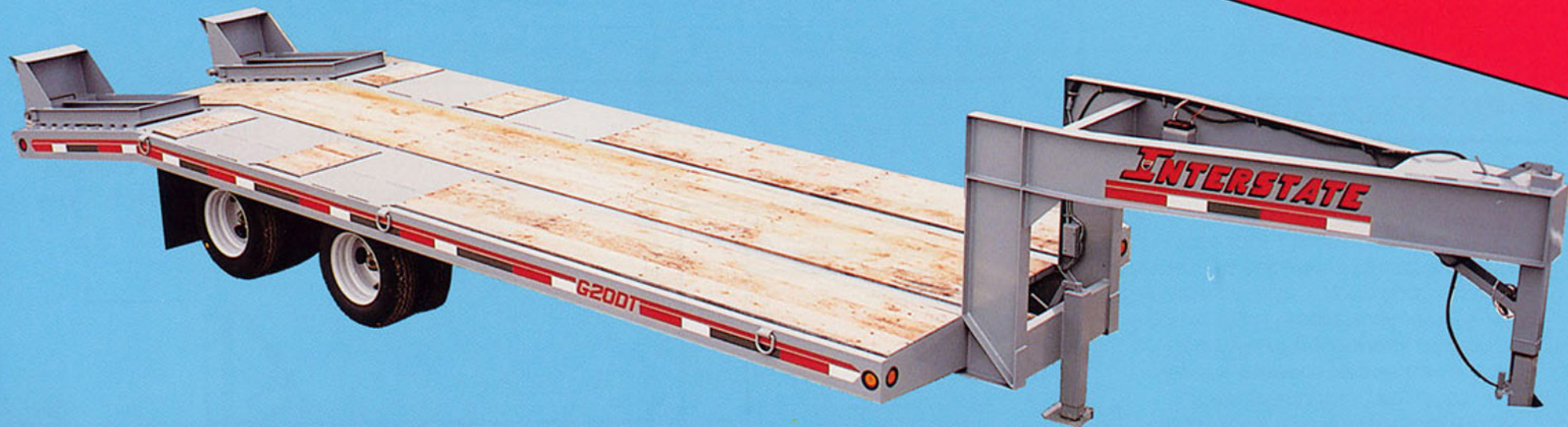

OPTIONS AVAILABLE

- MINI 5TH WHEEL
(WITH OPTIONAL RETRACTABLE KING PIN)
- 2 ⁵/₁₆" BALL HITCH COUPLER

G20DT

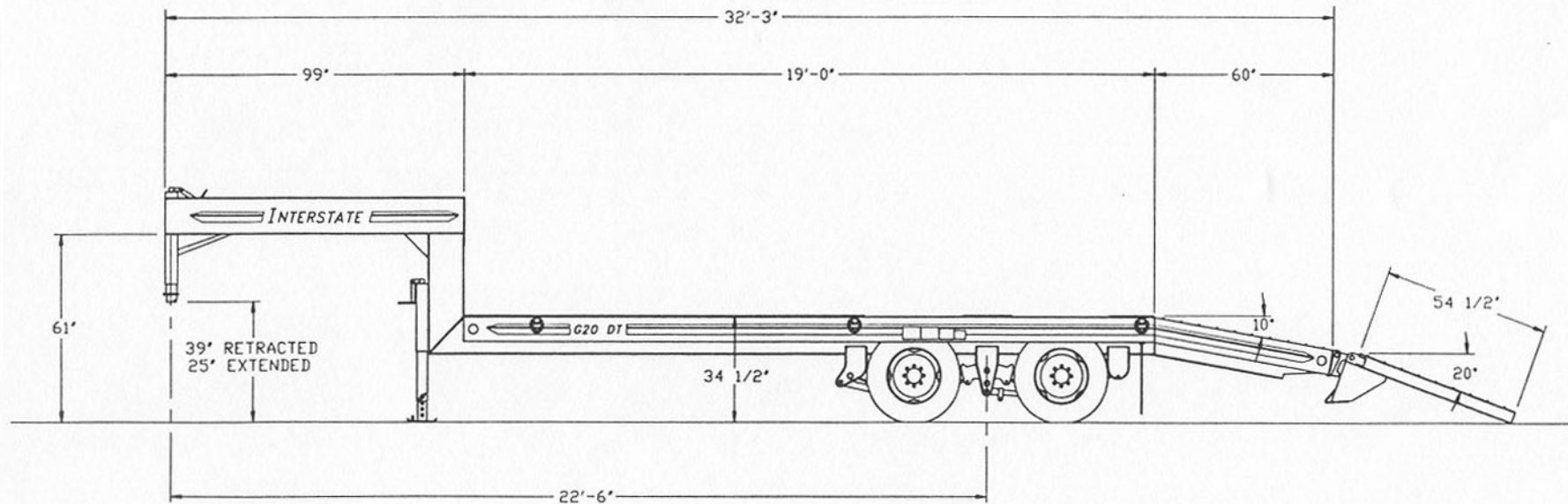

Model G20DT

CAPACITY:	20,000# @ 55 MPH	Decking:	2" Nominal Hardwood
Trailer Weight:	5,900#	Main Rails:	W12" x 16# A572 Gr. 50
Overall Length:	32'-3"	Crossmembers:	6" Jr. I Beam A572 Gr. 50
Overall Width:	96"/102"	Heavy Duty Axles:	(2) Each 10,000# Heavy Duty
Platform Length:	24' 0"	Heavy Duty Brakes:	Electric 12 1/4" x 4"
Platform Height:	34"	Exclusive Adjustable Suspension:	H9700 w/ Torque Arms
Dovetail Length:	60"	Tires:	245/75R x 16 - LRE
Ramp Length:	54 1/2"	Heavy Duty Wheels:	8 hole "Budd" Type Disc
Ramp Width:	21 1/2"	Lights & Electric:	Sealed Beam System/ICC & DOT Approved
		Hitch:	2-5/16" Ball Coupler

Break-A-Way Switch System with Gel Cell Battery
 Heavy Duty 12,000# Jack - Drop Leg

Interstate Trailers, Inc. reserves the right to change design, material and/or specifications without notice and without incurring any obligation to such changes.

Your **INTERSTATE** Dealer Is